

AUDIBLE BUZZER Mechanical

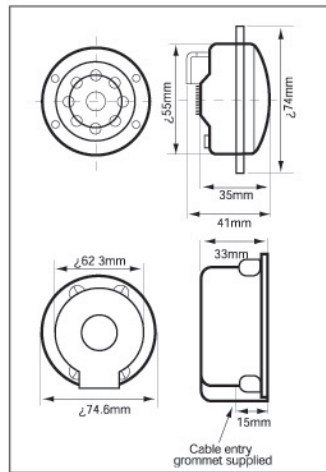

Code No:	Voltage:	Frequency:	Current:
AB50M-24A	24v Ac ~	100 Hz	600mA
AB50M-48A	48v Ac ~	100 Hz	300mA
AB50M-115A	115v Ac ~	100 Hz	120mA
AB50M-230A	230v Ac ~	100 Hz	90mA

AB50M-BB Weatherproof back-box ¥
 AB50M-BR Mounting Bracket



∞ On 20
 MINUTES MAX

dB 95

°C -20+50

IP 43/54¥

50/60 Hz

Kg 0.20

MOFLASH
 SIGNALLING LTD

Unit 18, Klaxon Industrial Estate
 Warwick Road, Tyseley,
 Birmingham B11 2HA
 England

Email: sales@moflash.co.uk
 Web: http://www.moflash.co.uk
 Tel: +44 (0) 121 707 6681
 Fax: +44 (0) 121 707 8305